

> YERÜSTÜ YANGIN HİDRANTI FIRE HYDRANT

FRH-0101



Basınç Sınıfı : PN16
Gövde : Pik döküm
Boru : Karbon çelik
Flanşlı

Pressure Rating : PN16
Body : Cast iron
Pipes : Carbon steel
Flanged

PRODUCT	SIZE
FRH-0101X100	1700 mm

CERTIFICATIONS

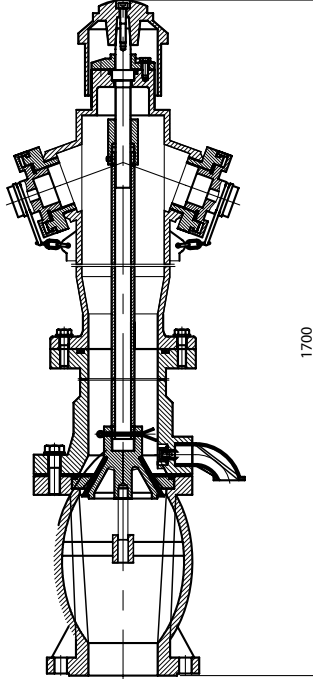

MALZEME / MATERIALS

Gövde / Body : Dökme demir / Cast iron
Klape / Disc : Dökme demir / Cast iron
Sit / Seat : Pirinç / Brass
Rot / Rot : Karbon çelik / Carbon steel
Mil Kafası / Stem Cap : Dökme demir / Cast iron
Mil Kılavuzu / Guide Stem : Paslanmaz çelik / Stainless steel

GENEL ÖZELLİKLER / GENERAL PROPERTIES

Basınç Sınıfı / Pressure Rating : PN16
Maksimum Çalışma Sıcaklığı / Maximum Working Temp. : 90 °C

DN	L
150	399