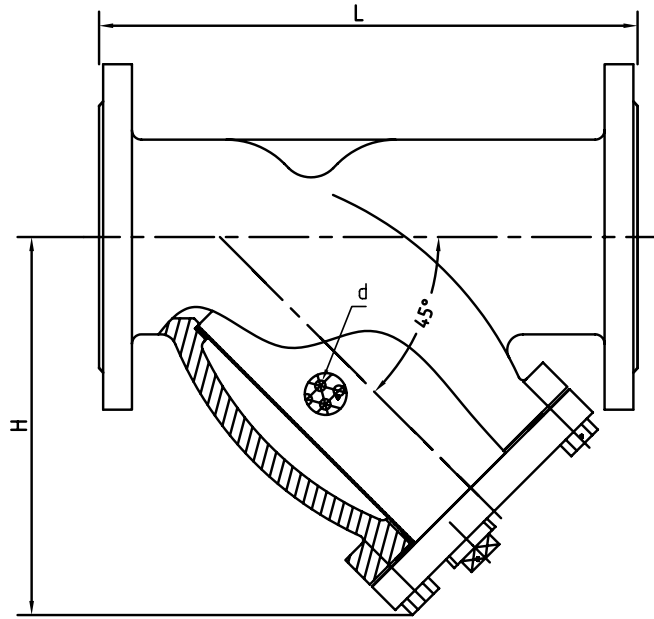

STR-0301**CERTIFICATIONS**

Basınç Sınıfı : PN25
 Gövde : Sfero döküm
 Filtre : Paslanmaz çelik
 Kapak : Boşaltma tapalı
 Conta : EPDM
 Flanşlı

Pressure Rating : PN25
 Body : Ductile iron
 Screen : Stainless steel
 Cover : With drain plug
 Seat : EPDM
 Flanged

PRODUCT	SIZE
STR-0301X050	DN 50
STR-0301X065	DN 65
STR-0301X080	DN 80
STR-0301X100	DN 100
STR-0301X125	DN 125
STR-0301X150	DN150
STR-0301X200	DN 200
STR-0301X250	DN 250
STR-0301X300	DN 300

**MALZEME / MATERIALS**

Gövde / Body : Sfero döküm / Ductile iron
 Kapak / Cover : Sfero döküm / Ductile iron
 Filtre / Screen : Paslanmaz çelik / Stainless steel
 Boşaltma Tapası / Flag : Sfero döküm / Ductile iron
 Conta / Gasket : EPDM
 Civata / Bolt : Karbon çelik / Carbon steel

GENEL ÖZELLİKLER / GENERAL PROPERTIES

Standart No : TS 11494
 Basınç Sınıfı / Pressure Rating : PN25
 Maksimum Çalışma Sıcaklığı / Maximum Working Temp. : Pik döküm +250 °C / Cast iron +250 °C
 Sfero döküm +300 °C / Ductile iron +300 °C

DN	L	H	d	TAPA / PLUG
50	230	146	Ø 1,5	1,2"
65	273	174	Ø 1,5	1"
80	295	198	Ø 1,5	1"
100	352	232	Ø 3	1"
125	416	285	Ø 3	1 1/4"
150	470	305	Ø 3	1 1/2"
200	543	401	Ø 3	1 1/2"
250	660	473	Ø 3	2"
300	770	554	Ø 3	2"