

Vertical Indicator Post For Valve 4" – 24"

FIG · F0600-IP

Specifications

- Indicates if the valve is in the OPEN or SHUT position.
- Provides a means to operate a buried or otherwise inaccessible valve.
- The adjustable dimension "L" is 34.5" to suit deeper buried valves. If more adjustment is required, specify at time of order.
- The wrench handle fits over a "U" bracket on the barrel and may be fixed to the barrel with a padlock (provided by others) for security.
- OPEN and SHUT targets can be easily adjusted to fit exactly in the viewing window.
- For use with gate valve size 4"-24".
- UL/ULC Listed and FM Approved.
- GOST Certification.

Corrosion Protection

- Internally and externally spray epoxy painted RAL3000.

Notes:

Design and material are subject to change without notice.

Material Specifications

No.	Component	Material
1	Hex Cap Screw	Carbon Steel ASTM A307B
2	Hex Nut	Carbon Steel ASTM A307B
3	Crane Coupling	Ductile Iron ASTM A536 Gr. 65-45-12
4	Cotter Pin	Stainless Steel AISI 304
5	Base Flange	Cast Iron ASTM A126 Class B
6	Hex Nut	Carbon Steel ASTM A307B
7	Hex Cap Screw	Carbon Steel ASTM A307B
8	Standpipe	Carbon Steel ASTM A53
9	Stem 1" Square	Carbon Steel AISI 1045
10	Body	Cast Iron ASTM A126 Class B
11	Locking Wrench	Ductile Iron ASTM A536 Gr. 65-45-12
12	Target Carrier Nut	Bronze ASTM B62 C83600 Stainless Steel AISI 304
13	Hex Cap Screw	Carbon Steel ASTM A307B
14	Hex Nut	Carbon Steel ASTM A307B
15	Hex Cap Screw	Carbon Steel ASTM A307B
16	Target	Cast Aluminium
17	Window Glass	Plexiglass
18	Gasket	PTFE
19	Operating Nut	Bronze ASTM B62 C83600 Stainless Steel AISI 304
20	Top Section	Cast Iron ASTM A126 Class B
21	Snap Ring	Carbon Steel AISI 1066
22	Plug	Malleable Iron
23	Square Nut	Carbon Steel ASTM A307B
24	Hex Cap Screw	Carbon Steel ASTM A307B

Schematic

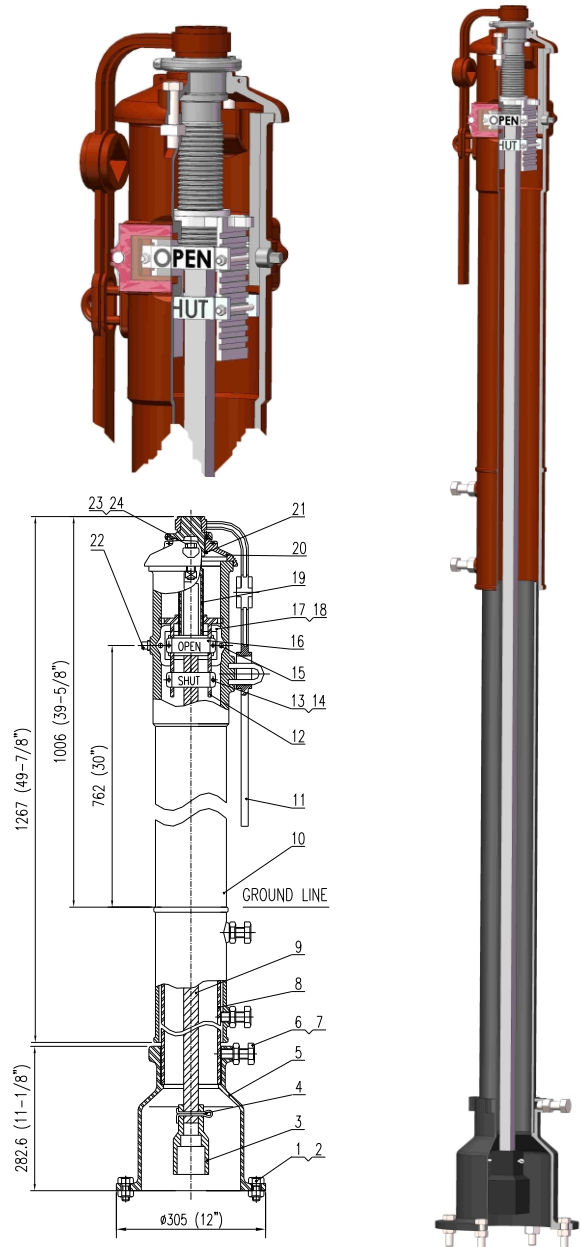

Field Adjustment

- Remove the top section of the upper barrel of the indicator post
- Cut the stem to the required length and adjust the standpipe to match up the GROUND LINE
- Set the OPEN and SHUT targets for the appropriate valve size
- Re-attach the top section of the upper barrel of the indicator post